

Application Note  
**AN 16-002**

Revision:	02
Issue date:	2019-08-06
Prepared by:	Rainer Weiss
Approved by:	Dr. Ulrich Nicolai

Keyword: isolation, insulation, dielectric, high voltage, test

# High voltage testing

- 1. General.....1
  - 1.1 High voltage type test.....1
  - 1.2 High voltage routine test.....2
- 2. High Voltage Testing.....2
  - 2.1 Test equipment.....2
  - 2.2 Test conditions .....2
  - 2.3 Tested insulation.....3
  - 2.4 Test procedure .....3
  - 2.5 Test voltage level.....7
  - 2.6 Test failures .....8
- 3. Differentiation to other Isolation Tests.....9
  - 3.1 Impulse voltage test.....9
  - 3.2 Partial discharge test .....9
  - 3.3 Insulation resistance test .....9

## 1. General

The goal of most electrical industry standards is to protect the user of equipment from electrical danger. For this purpose safety requirements for design and production have been established. Testing is used to evaluate these requirements. The most important test is the high voltage test. It is known by a number of names such as dielectric (strength) test, dielectric voltage-withstand test, flash test, high potential ("HiPot") test or isolation test.

### 1.1 High voltage type test

The proof of the design is done in a conformance (type) test. A high voltage is used to verify that the clearances and solid insulation of components have adequate dielectric strength to resist expected overvoltage conditions [3]. It also shows that the equipment is able to work safely over its complete lifetime. During the test the electrical stress on the insulation over its entire lifetime is simulated in a very short time. Here it is assumed that the failure mechanism at the end of life is the same as in the test. Using an empirical equation the lifetime stress is transferred to a test condition [4][5].

$$U_{operating\ voltage}^n \cdot T_{lifetime} = U_{test\ voltage}^n \cdot T_{test\ time}$$

This empirical equation is used in some standards to determine the conditions for a high voltage type test using an exponent of n=6. Typically the test voltage is calculated for an expected lifetime of 20 years. So equipment with an operating voltage of 230V has to be high voltage tested with a voltage of 3400V for one minute.

This also means that the tested insulation is maybe aged completely during the type test and cannot be used anymore. Therefore samples from high voltage type tests have to be scrapped or at least not be used if the safety of the user will be affected.

Normally the manufacturer of semiconductor modules increases the high voltage test time to some minutes for additional safety margin. However, this test typically does not bring the insulation to the end of its life. SEMIKRON tested modules with datasheet isolation values of  $3kV_{ac}/1min$  and  $4kV_{ac}/1min$  as well as  $5kV_{dc}$  for 1000h with no failures. After these tests, the voltage was increased in 1kV steps to  $9kV_{dc}$  when the device insulation failed instantly. Testing beyond the type test shows which voltages the design and the material of the module can take, but these test results should not be considered representative of all production modules.

## 1.2 High voltage routine test

The test conditions of a type test therefore cannot be used in a routine test. It is not the goal of a routine test to check if the equipment design is suited for the expected electrical stress on the insulation. Routine tests are carried out only to verify that clearances and solid insulation have not been reduced or damaged during the manufacturing operations or weak materials were used. To make sure that all insulation-related production failures can be excluded the high voltage routine test is done when production is completed and the equipment does not need to be reopened again. The test is not carried out to verify the insulation of the elementary components and also the creepage distances [6].

The specification of a routine test must be strong enough that safety-relevant failures are detected but only minimum ageing of the device occurs. Typical routine test specifications show that less than 0.000001% of the lifetime are aged by the test under the assumption that the empiric equation from 1.1 is valid.

If, for any reason, it is necessary to repeat the high voltage test, the level of voltage for the second test shall take into consideration that the high voltage test affects the quality of the insulation. Several standards recommend reducing the voltage to 80% [3] or 85% [6][7] of the first test level. High voltage tests with component data sheet values shall be avoided as well as routine incoming inspection tests.

The typical test periods of high voltage routine test are 1s or 5s. Though occasionally longer test periods like 60s are specified. For semiconductor devices UL1557 describes the possibility to shorten the test period by increasing the test voltage. The rated voltage with a test time of 60s is increased to 120% for 1s [8].

The test conditions for the SEMIKRON high voltage test are given in the datasheet (typically with the  $V_{isol}$  parameter). If the given test duration is 5s or 60s it is the type test condition. Shorter test durations like 1s and 3s are routine test conditions.

## 2. High Voltage Testing

### 2.1 Test equipment

Several suppliers offer high voltage test equipment. The main differences are

- the maximum applied voltage,
- the maximum applied current and
- the options of a.c. and d.c. voltage.

More or less all available instruments fulfill the requirements for test equipment specified in EN 61180 [9]. Besides the voltage quality it is recommended that the short-circuit output current of the equipment is not less than 200mA [10]. For UL a transformer with at least 500VA is enough to sustain the voltage during the test [8].

### 2.2 Test conditions

Normally the high voltage test is performed with a sinusoidal voltage at 50Hz or 60Hz. If the circuit contains capacitors the test may be performed with a d.c. voltage equal to the peak value of the specified a.c. voltage. The d.c. voltage test is not fully equivalent to the a.c. voltage test due to the different withstand characteristics of solid insulation for these types of voltages [10]. The polarity of the test voltage has an impact on the flashover voltage. For d.c. tests it is necessary to check both polarities [4].

Semiconductor modules with large base plates can have relatively large capacitances (up to  $\approx 10nF$ ) between both sides of their substrate. For these modules d.c. tests are recommended.

The d.c. high voltage test is advised for production facilities. A d.c. current is less risky for the human heart in case of an accident. Additional workplace safety measures are not needed during high voltage testing with a.c. up to 3mA and d.c. up to 12mA [11]. The d.c. high voltage test, thus, has the advantage that no extra precautions are required for tests of 12mA or less. If the current is higher a special test room or a sealed off area with warning light and two-handed operation is required in many countries.

A few standards request specified ambient conditions for the high voltage test. Typical values are 15°C to 35°C ambient temperature, 45% to 75% relative humidity and an air pressure of 860hPa up to 1060hPa.

## 2.3 Tested insulation

Test samples can contain several circuits which may be galvanically isolated from each other. The insulation within and between these circuits is categorized for safety requirements:

- Functional insulation separates potentials within a circuit and considers purely functional, but not safety relevant aspects. [12]
- Basic insulation separates grid supplied circuits from earthed exposed parts and is thus vital for safety. A breakdown of the insulation does not result automatically in a danger of life due to the earthing of the exposed parts [12]
- Protective separation realized by reinforced or double (two times basic) insulation separates grid supplied circuits from unearthed exposed parts, on the one hand, and from control circuits, if they are directly connected to other control circuits which have exposed components. No further protection is provided for equipment users. A breakdown of this insulation could be fatal because the unearthed exposed parts can be shifted to the grid voltage. This is the reason why stricter safety requirements must be fulfilled. [12]

The high voltage test is applied only on safety-relevant basic insulation and protective separation. Non safety-relevant functional insulation is not tested by the high voltage test.

## 2.4 Test procedure

Most standards for electrical equipment demand the following conditions for the test:

- External terminals of the circuit shall be connected together.
- Switchgear and controls within equipment shall be in the closed position or bypassed.
- Terminals of voltage blocking components (such as rectifier diodes) shall be connected together.

It is mandatory to connect all test sample terminals of the same circuit with each other for the high voltage test. These are the a.c. and d.c. terminals of the converter shown here [Figure 1].

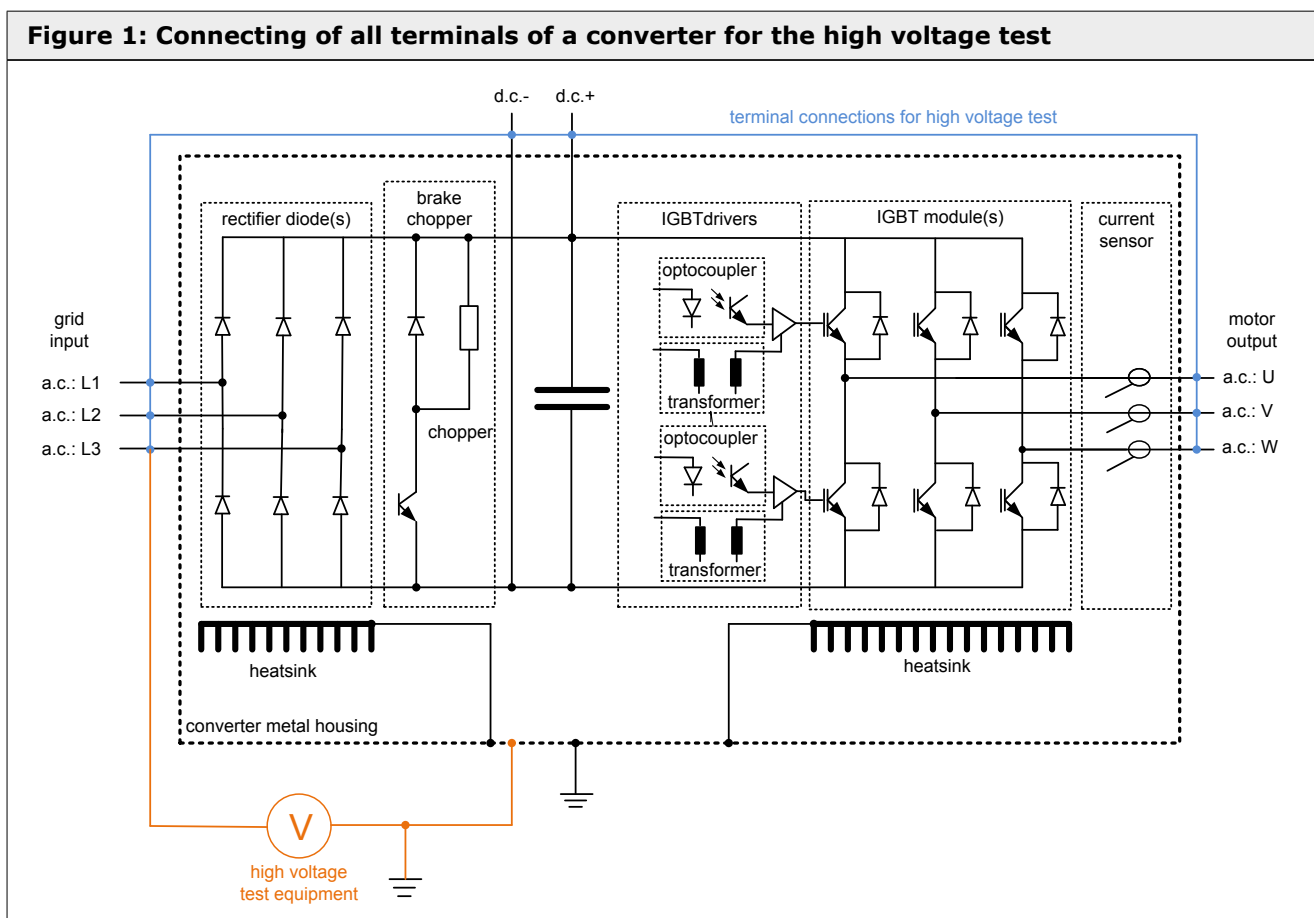

If the test sample consists of more circuits which are isolated from each other with basic insulation or protective separation it will be necessary to test all circuits to their surroundings. The meaning of "surroundings" here is all adjacent circuits plus earth. Non earthed conductive parts that can be touched

are separate circuits by definition. Circuits with the same test voltage can be connected and tested together. However more than one high voltage test may be necessary for the test sample. The connection of circuits may be different for type and routine tests if they require different test voltages.

**Figure 2: Connecting of separate circuits of a converter to minimize the number of high voltage tests**

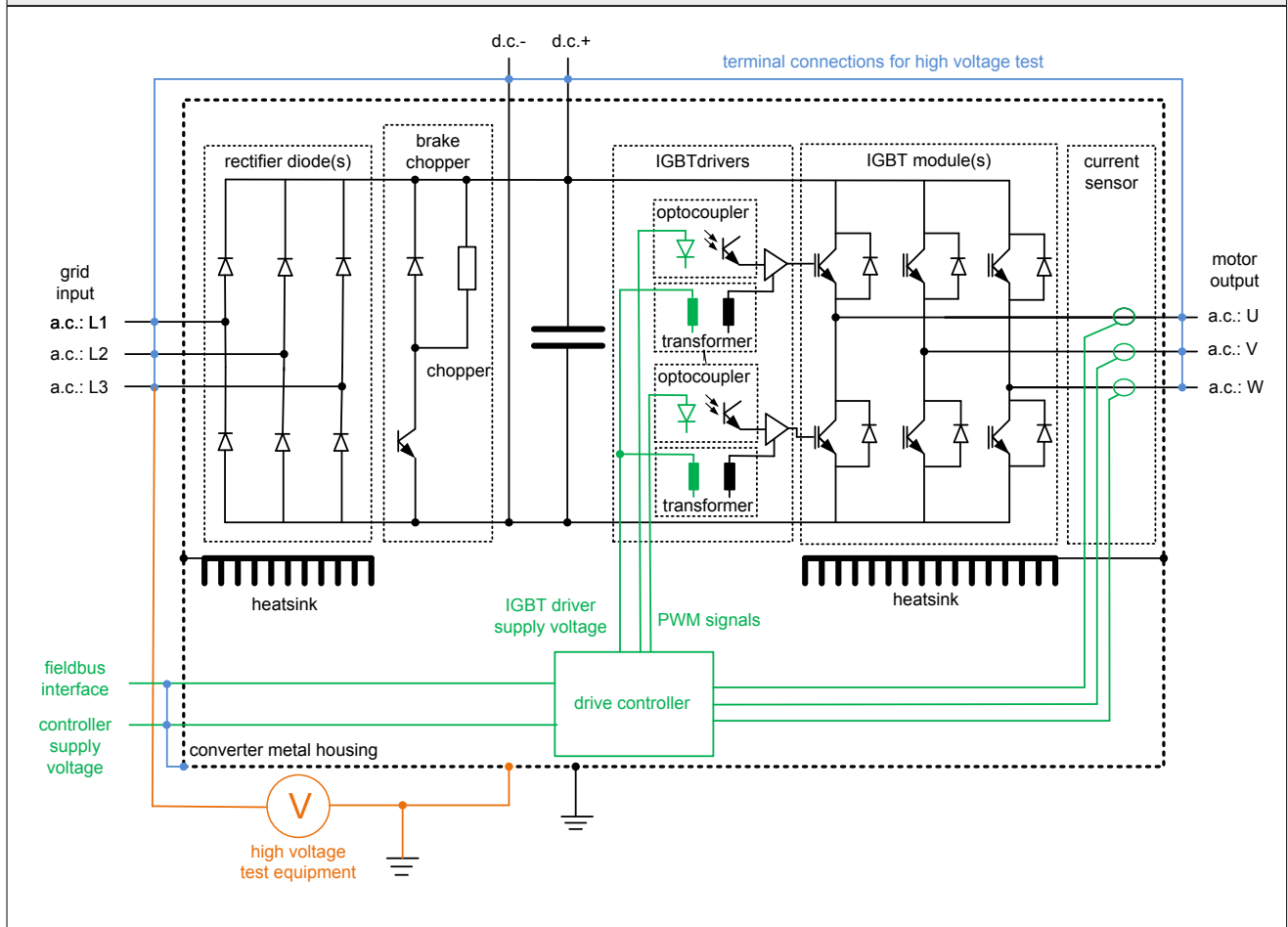

The power circuit is connected with the grid and has basic insulation to earth. The green circuit shown here is for the drive control [Figure 2]. It has protective separation from the power circuit. The voltage between drive control circuit and earth is below 50V. So the control circuit and earth can be connected with each other for the high voltage test if the test voltage and the test duration for basic insulation and protective separation are the same. If the test voltage level is different both circuits have to be tested separately. The temperature sensor of power modules normally has only functional insulation to the power circuit unless stated differently in the product datasheet. This means that for high voltage testing the sensor shall be connected to the power circuit. If it is connected with the drive controller circuit and passes the high voltage test it is not valid to conclude that the insulation between sensor and power circuit fulfills the needs of protective separation.

If the requirement of connecting all terminals with each other is not followed semiconductors may be damaged in case of a test fault outside of the module. The voltage level in the test is usually higher than the blocking voltage of the semiconductor. So the test voltage exceeds the device (e.g. diode) voltage rating when the insulation fails anywhere in the d.c. link and the test voltage supply is connected to an a.c. terminal only. In this example the full test voltage is connected to the diode and causes it to fail as a result of the disconnected d.c. terminals [Figure 3].

**Figure 3: Semiconductor overvoltage in case of an isolation fault in high voltage test**

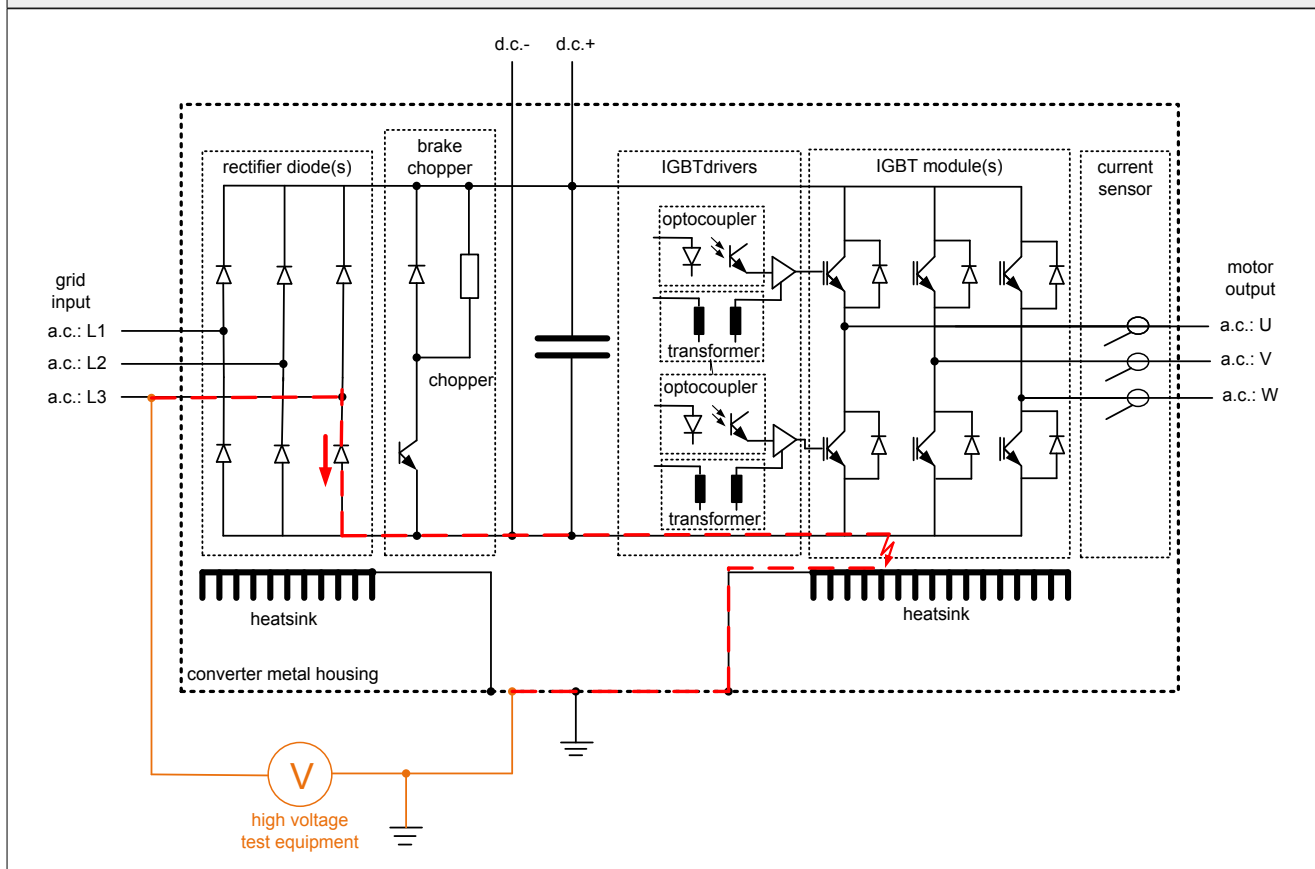

Surge protective devices must be disconnected before high voltage testing. If capacitors with high capacitance are parallel to the parts between where the test voltage needs to be applied, it may be difficult, or even impossible, to perform the a.c. voltage test because the charging current would exceed the capacity or current set point of the voltage tester. In the latter case, those parallel capacitors could be disconnected before testing. If this is also impossible, d.c. testing can be taken into consideration [10].

Table 1 gives an overview of the requirements for the high voltage test of the most relevant standards for power electronics:

- drives [3][23]
- uninterruptible power systems (UPS) [13]
- photovoltaic power systems [14]
- power installations [7][10][15][16][22]
- railway applications [6][17]
- information technology [18]
- power semiconductors [8][20]

The data of Table 1 is valid for basic insulation with voltages up to 1000V.

<b>Table 1: Overview high voltage test conditions of several standards</b>					
	connection of all terminals	disconnection of components	voltage type	test time	failure criteria
EN 50124-1 [17]	shall	-	a.c. or d.c. *	5s	no sparkover or breakdown
EN 50178 [15]	optional	forbidden for capacitors, permitted for voltage sensitive device like semiconductors	a.c. or d.c.	60s type 5s routine	no puncture, flashover or sparkover
EN 60664-1 [10]	shall	-	a.c. or d.c. * in both polarities	3 cycles for a.c. 10ms for d.c.	no puncture or breakdown
EN 60747-15 [20]	shall	-	-	-	test current below specified level
IEC 60950-1 [18]	optional	permitted for: -discharge resistors, -filter capacitors, -voltage limiting devices, -surge suppressors	a.c. or d.c. *	60s type 1s routine	Current increases rapidly in an uncontrolled manner. Corona discharge or single momentary flashover is no failure. [5.2.2]
EN 61287-1 [6]	shall	-	a.c. or d.c. *	60s type and routine	-
EN 61439-1 [7]	shall	forbidden for capacitors	a.c.	5s type 1s routine	no puncture, flashover or sparkover
EN 61800-5-1 [3]	shall	permitted for protective device, monitoring circuit, semiconductors	a.c. or d.c.	5s type 1s routine	no electrical breakdown
EN 62040-1 [13]	same as IEC 60950-1				
EN 62109-1 [14]	shall	permitted for protective device, monitoring circuit, semiconductors	a.c. or d.c. *	5s type 1s routine	no electrical breakdown
IEC 62477-1 [16]	shall	permitted for protective device, monitoring circuit, semiconductors	a.c. or d.c. *	60s type 1s routine	no electrical breakdown
UL 1557 [21]	shall	-	a.c.	60s type and routine or 1s 120% routine only	no breakdown
UL 1741 [22]	optional	-	a.c. or d.c. **	60s type and routine	no breakdown
UL 61800-5-1 [23]	shall	permitted for protective device, monitoring circuit, semiconductors	a.c. or d.c. **	60s type no routine test	no electrical breakdown

\* equal to peak voltage of a.c.

\*\* equal 1.414 times voltage of a.c.

## 2.5 Test voltage level

The voltage level in the high voltage test is determined by the operating voltage of the equipment. For this the grounding of the connected grid is important. In a star grounded (TN) grid the voltage stress for the insulation is lower (e.g. 230V in a 3-phase system with 400V line-to-line voltage) than in a corner grounded grid with the same line-to-line voltage (here 400V).

In Table 2 the a.c. test voltage levels for basic insulation in equipment connected to a star grounded grid are shown according to the most relevant standards for power electronics. Also given are the levels for type tests and routine tests for typical grid voltages.

<b>Table 2: Overview high voltage test a.c. levels (rms) for basic insulation of equipment for star grounded grids in several standards</b>							
	formular for test voltage calculation	230V+10%		480V+10%		690V+10%	
		type	routine	type	routine	type	routine
EN 50124-1 [17]		1390V	1043V	2210V	1658V	3320V	2490 V
EN 50178 [15]	$1.5 \cdot U + 750V$	1133V		1470V		1900V	
EN 60664-1 [10]	-	2065V		3482V		5222V	
EN 60747-15 [20]	see endproduct standard						
IEC 60950-1 [18]	-	1500V	1350V	2500V	2250V	4000V	3600V
EN 61287-1 [6]	$2 \cdot U_{peak}/\sqrt{2} + 1000V$	1506V		1610V		1880V	
EN 61439-1 [7]	-	-	2000V	-	2500V	-	3000V
EN 61800-5-1 [3]	$U + 1200V$	1453V		1505V		1640V	
EN 62040-1 [13]	same as IEC 60950-1						
EN 62109-1 [14]	$U + 1200V$	1453V		1505V		1640V	
IEC 62477-1 [16]	$U + 1200V$	1453V		1505V		1640V	
UL 1557 [21]	specified isolation voltage of product						
UL 1741 [22]	$2 \cdot U + 1000V$	1460V	-	1960V	-	2380V	-
UL 61800-5-1 [23]	-	1460V	-	1960V	-	3553V	-

The voltage level spread between the standards is wide (more than a factor of 3). The goal of the semiconductor module manufacturer is to specify the isolation rating of the modules so high that it matches the requests of all relevant standards. This is much higher what most applications need.

Test voltage levels for safety insulation can differ from these values considerably. In general they are higher for the type test.

**Table 3: Overview of high voltage test a.c. levels (rms) for protective separation of equipment for star grounded grids**

	230V+10%		480V+10%		690V+10%	
	type	routine	type	routine	type	routine
EN 50124-1 [17]	2210V	1658V	3500V	2625V	4870V	3653V
EN 50178 [15]	1133V		1470V		1900V	
EN 60664-1 [10]	4130V		6964V		10 444V	
EN 60747-15 [20]	see endproduct standard					
IEC 60950-1 [18]	3000V	2700V	5000V	4500V	8000V	7200V
EN 61287-1 [6]	1506V		1610V		1880V	
EN 61439-1 [7]	-	2000V	-	2500V	-	3000V
EN 61800-5-1 [3]	2906V	1453V	3010V	1505V	3280V	1640V
EN 62040-1 [13]	same as IEC 60950-1					
EN 62109-1 [14]	2906V	1453V	3010V	1505V	3280V	1640V
IEC 62477-1 [16]	2906V	1453V	3010V	1505V	3280V	1640V
UL 1557 [21]	specified isolation voltage of product					
UL 1741 [22]	1460V	-	1960V	-	2380V	-
UL 61800-5-1 [23]	2906V	-	3010V	-	3280V	-

Semiconductor modules have no integrated protective separation. Therefore the test levels given here are relevant for equipment testing only.

The test voltage must be increased continuously to the maximum level within a minimum time period.

Some standards define this time, e.g. 5s minimum time [10][17].

## 2.6 Test failures

Different words are used in the standards for defining the various failure modes:

- An **electrical breakdown** is a failure of insulation under electrical stress when the discharge completely bridges the insulation, thus reducing the voltage between the electrodes almost to zero [3]
- **disruptive discharge**: passage of an arc following dielectric breakdown [24]
- **sparkover**: disruptive discharge in a gaseous or liquid dielectric [24]
- **flashover**: disruptive discharge over the surface of a solid dielectric surrounded by a gaseous or liquid medium [24]
- **puncture**: disruptive discharge through a solid dielectric [24]

The failure criteria for the high voltage test vary in the different standards and also partially contradict each other. The test is considered successfully passed if:

- No disruptive discharge (sparkover, flashover or puncture) occurs [10]. A leakage current that is monitored during the test is not exceeded.
- No breakdown [21] or insulation breakdown [3] occurs.
- The test current doesn't increase rapidly in an uncontrolled manner. Corona discharge or a single momentary flashover is not regarded as insulation breakdown [18].

Due to these differences the failure criteria of the product relevant standard must be taken into account. A general failure criterion is not defined.



### 3. Differentiation to other Isolation Tests

#### 3.1 Impulse voltage test

The impulse voltage test is intended to simulate overvoltages of atmospheric origin. It also covers overvoltages due to switching of equipment. The test is successfully passed if no puncture, flashover, or sparkover occurs [3]. It is used to verify that the clearances and solid insulation of components have adequate dielectric strength. Advantage of this test is the very short test time that minimizes the electrical stress for the insulation. This prevents any ageing effect on the component.

Solid insulation has a different withstand characteristic compared to clearance if the time of stress is increased. In general the withstand capability will be decreased significantly. Therefore the high voltage test, which is specified for the verification of the withstand capability of solid insulation, is not allowed to be replaced by an impulse voltage test. The impulse voltage test is not able to check if the insulation of components will work safely during the complete lifetime as in the high voltage type test.

#### 3.2 Partial discharge test

The partial discharge test must confirm that the solid insulation used in components and subassemblies remains partial-discharge-free with the specified voltage range [3]. Partial discharges in clearances which do not result in breakdown are disregarded [10]. This test does not detect sparkover and the test level is normally lower than overvoltages that can be expected from atmospheric origin.

Partial discharge tests for solid insulation must be specified if the applied peak value exceeds 700V and if the average field strength is higher than 1kV/mm [10].

#### 3.3 Insulation resistance test

The measurement of the insulation resistance is done to evaluate the general condition of the insulation. It is normally made during regular maintenance and any additional ageing effect from testing should be prevented. The measurement result gives an indication of ageing of the insulation by comparison with previous results (over a period of years) but no hint to weaknesses in the isolation system [19]. Reduced clearances of equipment and consequential flashovers are not tested here due to test voltages being far below expected overvoltages of atmospheric origin.

Only the impulse voltage test will detect unintended insulation weaknesses as well as the high voltage routine test.

Figure 1: Connecting of all terminals of a converter for the high voltage test .....3  
 Figure 2: Connecting of separate circuits of a converter to minimize the number of high voltage tests .....4  
 Figure 3: Semiconductor overvoltage in case of an isolation fault in high voltage test .....5

Table 1: Overview high voltage test conditions of several standards .....6  
 Table 2: Overview high voltage test a.c. levels for basic insulation of equipment for star grounded grids in several standards .....7  
 Table 3: Overview of high voltage test a.c. levels for protective separation of equipment for star grounded grids.....8

**References**

[1] www.SEMIKRON.com  
 [2] A. Wintrich, U. Nicolai, W. Tursky, T. Reimann, "Application Manual Power Semiconductors", ISLE Verlag 2015, ISBN 978-3-938843-83-3  
 [3] EN61800-5-1: 2017, "Adjustable speed electrical power drive systems – Part 5-1: Safety requirements – Electrical, thermal and energy"  
 [4] Wolfgang Pfeiffer, "Isolationskoordination in Niederspannungsbetriebsmitteln", VDE-Verlag 1998, ISBN 3-8007-2181-3  
 [5] Klecszty, S. E., "Formal theoretical foundation of electrical ageing of dielectrics", IEEE Transactions on Power Apparatus and Systems 100, 1981  
 [6] EN 61287-1: 2007-08, "Railway applications – Power converter installed on board rolling stock – part 1: Characteristics and test methods"  
 [7] EN 61439-1: 2012\_06, "Low-voltage switchgear and controlgear assemblies – Part 1: General rules"  
 [8] UL 1557: 2011-12-29, "Electrically isolated semiconductor devices"  
 [9] EN 61180:2013-07, "High-voltage test techniques for low-voltage equipment – definitions, test and procedure requirement, test equipment"  
 [10] EN 60664-1: 2008-01, "Insulation coordination for equipment within low-voltage systems – Part1: Principles, requirements and tests"  
 [11] EN 50191: 2011-10, "Erection and operation of electrical test equipment"  
 [12] R. Weiss, "Insulation coordination", SEMIKRON application note, AN1405 – rev02, Nuremberg, 2014  
 [13] EN 62040-1: 2013-11, "Uninterruptible power systems (UPS) – Part 1: General and safety requirements for UPS"  
 [14] EN 62109-1: 2011-04, "Safety of power converters for use in photovoltaic power systems – Part 1: General requirements"  
 [15] EN 50178: 1997, "electronic equipment for use in power installations"  
 [16] IEC 62477-1: 2017, "Safety requirements for power electronic converter systems and equipment - Part 1: General"  
 [17] EN 50124: 2016-03, "Railway applications – Insulation coordination – Part 1: Basic requirements - Clearances and creepage distances for all electrical and electronic equipment"  
 [18] IEC 60950-1: 2005-12: "Information technology equipment – Safety – Part 1: General requirements"  
 [19] IEC 2/1776/CD:2014, "Rotating electrical machines – Part 27-4: Measurements of insulation resistance and polarization index on winding insulation of rotating electrical machines"  
 [20] EN 60747-15: 2010, "Semiconductor devices – Discrete devices – Part 15: Isolated power semiconductor devices"  
 [21] UL 1557: 2011-12-29, "Electrically isolated semiconductor devices"  
 [22] UL 1741: 2010-01-28, "Inverters, converters, controllers and interconnection system equipment for use with distributed energy resources"  
 [23] UL 61800-5-1: 2012-06-08, "Adjustable Speed Electrical Power Drive Systems – Part 5-1: Safety Requirements - Electrical, Thermal and Energy"  
 [24] IEC 61000-2-14: 2007-01-31, "Electromagnetic compatibility (EMC) – Environment.- Overvoltages on public electricity distribution networks"

## Symbols and Terms

Letter Symbol	Term
hPa	hecto Pascal; $1\text{hPa} = 100\text{N} / \text{m}^2 = 100\text{kg} / \text{m} \cdot \text{s}^2$
$V_{\text{isol}}$	SEMIKRON high voltage test voltage [ $V_{\text{rms}}$ ] in type or routine test

A detailed explanation of the terms and symbols can be found in the "Application Manual Power Semiconductors" [2]

## IMPORTANT INFORMATION AND WARNINGS

The information in this document may not be considered as guarantee or assurance of product characteristics ("Beschaffheitsgarantie"). This document describes only the usual characteristics of products to be expected in typical applications, which may still vary depending on the specific application. Therefore, products must be tested for the respective application in advance. Application adjustments may be necessary. The user of SEMIKRON products is responsible for the safety of their applications embedding SEMIKRON products and must take adequate safety measures to prevent the applications from causing a physical injury, fire or other problem if any of SEMIKRON products become faulty. The user is responsible to make sure that the application design is compliant with all applicable laws, regulations, norms and standards. Except as otherwise explicitly approved by SEMIKRON in a written document signed by authorized representatives of SEMIKRON, SEMIKRON products may not be used in any applications where a failure of the product or any consequences of the use thereof can reasonably be expected to result in personal injury. No representation or warranty is given and no liability is assumed with respect to the accuracy, completeness and/or use of any information herein, including without limitation, warranties of non-infringement of intellectual property rights of any third party. SEMIKRON does not assume any liability arising out of the applications or use of any product; neither does it convey any license under its patent rights, copyrights, trade secrets or other intellectual property rights, nor the rights of others. SEMIKRON makes no representation or warranty of non-infringement or alleged non-infringement of intellectual property rights of any third party which may arise from applications. This document supersedes and replaces all information previously supplied and may be superseded by updates. SEMIKRON reserves the right to make changes.

SEMIKRON INTERNATIONAL GmbH  
Sigmundstrasse 200, 90431 Nuremberg, Germany  
Tel: +49 911 6559 6663, Fax: +49 911 6559 262  
sales@semikron.com, www.semikron.com